

With reference to designer's duties under the Construction (Design and Management) Regulations 2007, design teams are reminded to use a hierarchy of control, so far as is reasonably practical, to i) eliminate the hazard, ii) reduce the risk iii) provide relevant information. Key risks include manual handling and dust inhalation.

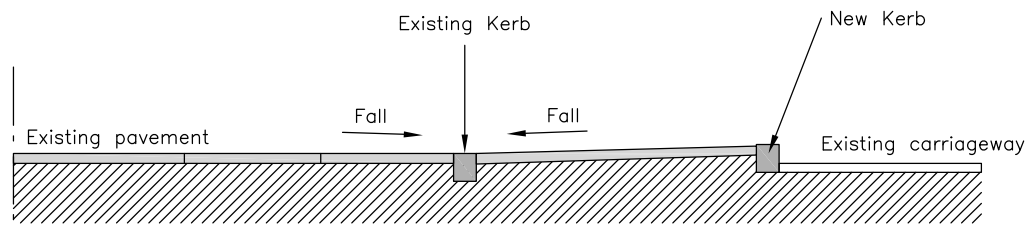

Section A-A  
Not to scale

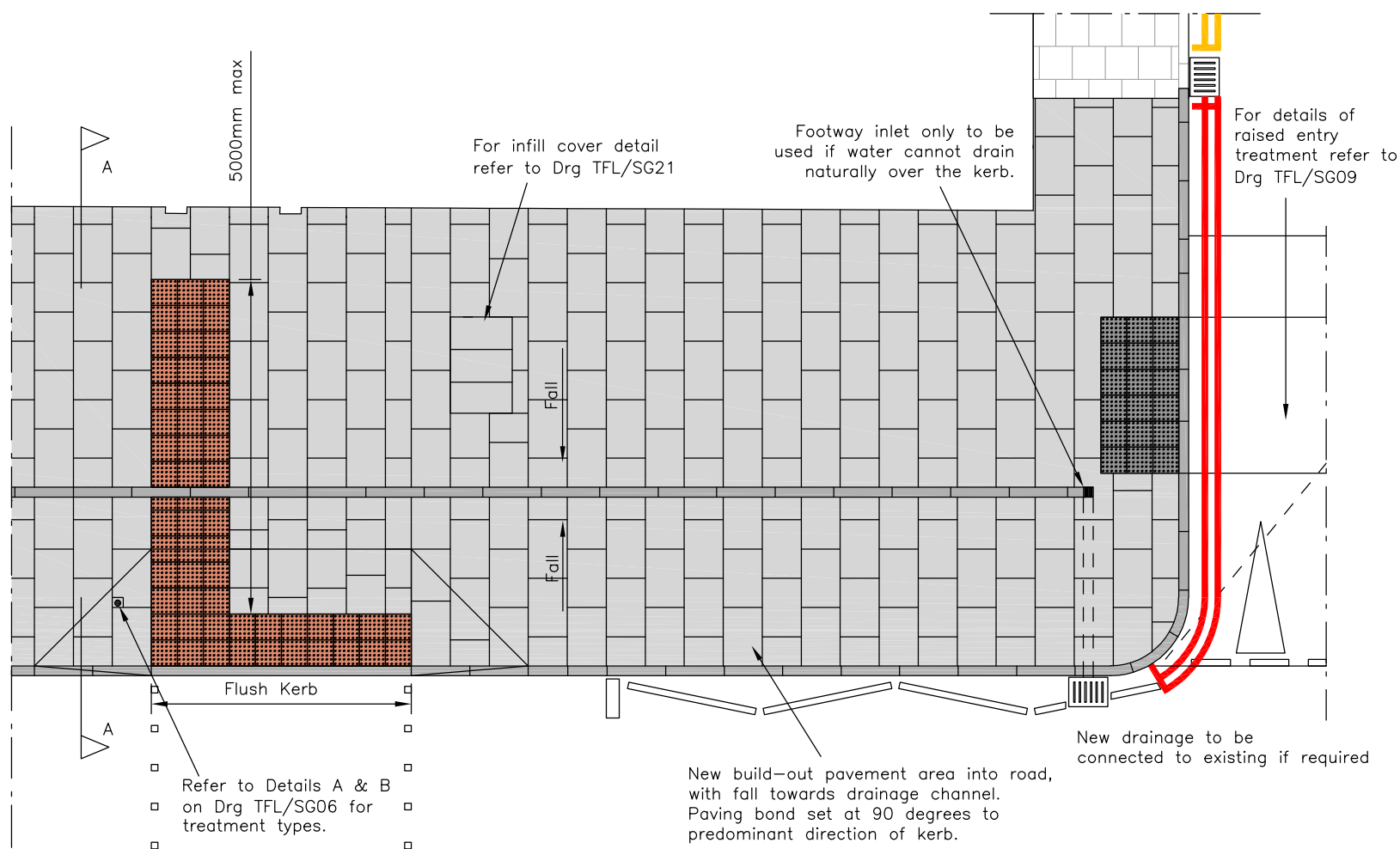







Plan  
Scale 1:100

Notes

1. All paving to be laid on a 150mm thick type c7.5p concrete sub base extending 1000mm from back of kerb unless otherwise specified. The remaining area of footway to be laid on 100mm thick type c7.5p concrete sub base unless otherwise stated. All concrete flags and tactile paving to be bedded on a 30mm sand/cement mortar mix, butt jointed, with dry sand brushed into joints. The Resident Engineer should be advised where the preferred depth of construction cannot be achieved on site.
2. Concrete flags to be laid with courses set at 90° to kerb and a minimum overlap bond of 150mm.
3. The bonding of paving to be cut around utility service covers unless directed by the Resident Engineer.
4. Concrete flags should not be cut so that a width less than 300mm remains. Previous courses should be cut to distribute evenly over width.
5. Granite kerbs to be fine picked 150mm x 300mm x 900-1200mm long. Standard kerb height to be 125mm above carriageway.
6. Kerb dropped over approximately 1800mm to provide a flush fine picked silver grey kerb (0mm upstand) over crossing width.
7. Existing utility service covers in paved areas to be replaced with recessed covers and infilled with matching paving. Covers to be adjusted to suit on site as directed by the Resident Engineer. (Ref Dwgs TFL/SG21 & SG22)
8. Lateral clearance to all street furniture to be 450mm minimum from face of kerb.
9. All work to be carried out in compliance with the requirements of The Manual Handling Operations Regulations 1992 (as amended in 2002).

Legend

-  Red blister paving: concrete modular, 400x400x65mm
-  Charcoal grey blister paving: concrete modular, 400x400x65mm
-  150mm Granite kerb, fine picked
-  Concrete flag, nominally 900x600x65mm
-  Existing footway
-  Road markings in thermoplastic screed or equivalent

6	30/06/08	GUIDANCE ISSUE No 2	MDR	CNR
5	19/05/08	MINOR AMENDMENTS	MDR	CNR
4	02/04/08	MINOR AMENDMENTS	MDR	CNR
3	17/12/07	MINOR AMENDMENTS	GSV	LD
2	10/08/05	GUIDANCE ISSUE No 1	SK	RD
1	02/08/05	CLIENT AMENDMENTS	RD	IH
0	25/02/05	Original Issue	RD	IH
Rev.	Date	Description	Chkd.	App.



Project  
Streetscape Guidance

Drawing Title  
Footway Buildout-  
Drainage Details

Drawing Status  
**GUIDANCE ISSUE No 2**

Drawn PCL	Designed TFL	Scale As shown	Size A3
Drawing No. TFL/SG12			Rev 6

With reference to designer's duties under the Construction (Design and Management) Regulations 2007, design teams are reminded to use a hierarchy of control, so far as is reasonably practical, to i) eliminate the hazard, ii) reduce the risk iii) provide relevant information. Key risks include manual handling and dust inhalation.

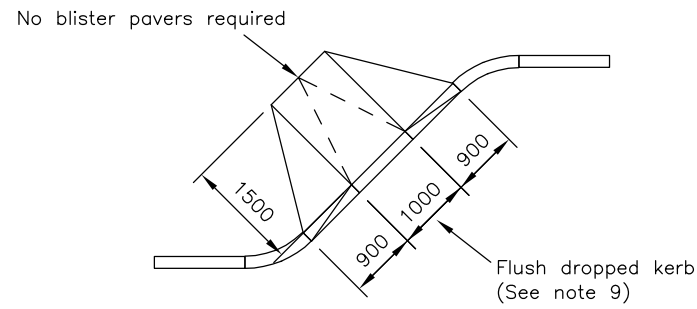

Detail A  
Not to scale

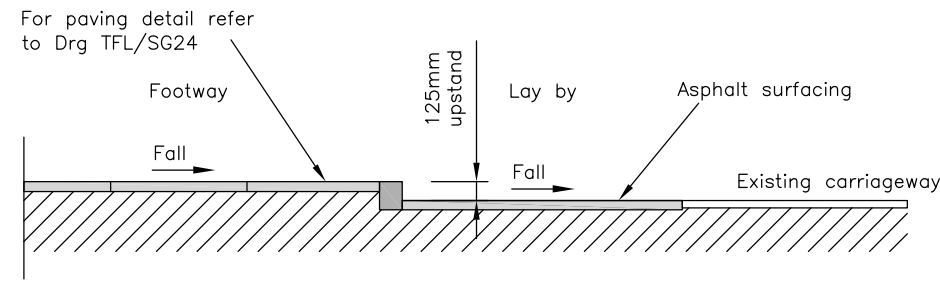

Section A-A  
Not to scale

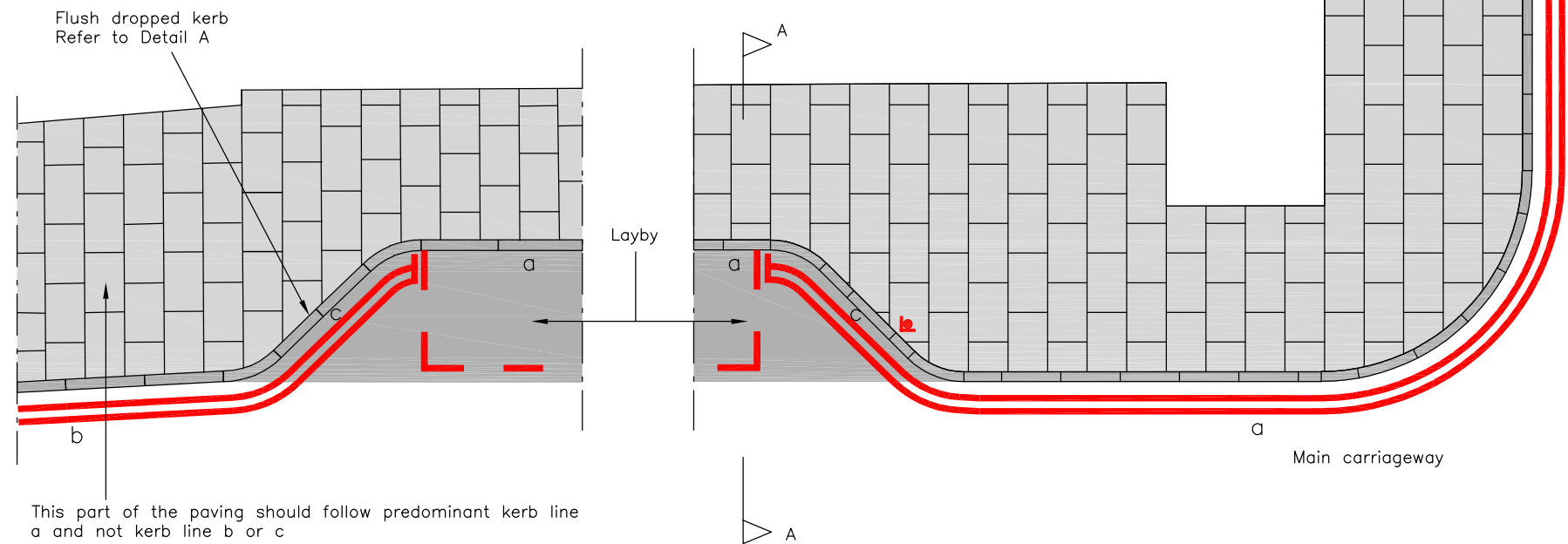

This part of the paving should follow predominant kerb line a and not kerb line b or c

The predominant kerb face should be taken as line for perpendicular paving; ideally this should not change

Plan of Layby  
Scale 1:100

Notes

- All paving to be laid on a 150mm thick type c7.5p concrete sub base extending 1000mm from back of kerb unless otherwise specified. The remaining area of footway to be laid on 100mm thick type c7.5p concrete sub base unless otherwise stated. All concrete flags and tactile paving to be bedded on a 30mm sand/cement mortar mix, butt jointed, with dry sand brushed into joints. The Resident Engineer should be advised where the preferred depth of construction cannot be achieved on site.
- Concrete flags to be laid with courses set at 90° to kerb and a minimum overlap bond of 150mm.
- The bonding of paving to be cut around utility service covers unless directed by the Resident Engineer.
- Concrete flags should not be cut so that a width less than 300mm remains. Previous courses should be cut to distribute evenly over width.
- Granite kerbs to be fine picked 150mm x 300mm x 900–1200mm long. Standard kerb height to be 125mm above carriageway.
- Existing utility service covers in paved areas to be replaced with recessed covers and infilled with matching paving. Covers to be adjusted to suit on site as directed by the Resident Engineer. (Ref Dwgs TFL/SG21 & SG22)
- Lateral clearance to all street furniture to be 450mm minimum from face of kerb.
- All work to be carried out in compliance with the requirements of The Manual Handling Operations Regulations 1992 (as amended in 2002).
- Kerb dropped over approximately 900mm to provide flush kerb (0mm upstand).

Legend

- 150mm Granite kerb, fine picked
- Concrete flag, nominally 900x600x65mm
- Asphalt surfacing
- Road markings in thermoplastic screed or equivalent
- Bi-directional waiting restriction sign

6	30/06/08	GUIDANCE ISSUE No 2	MDR	CNR
5	19/05/08	MINOR AMENDMENTS	MDR	CNR
4	02/04/08	MINOR AMENDMENTS	MDR	CNR
3	10/01/08	MINOR AMENDMENTS	GSV	LD
2	10/08/05	GUIDANCE ISSUE No 1	SK	RD
1	10/06/05	MINOR AMENDMENTS	RD	IH
0	25/02/05	Original Issue	RD	IH
Rev.	Date	Description	Chkd.	App.



Project  
Streetscape Guidance

Drawing Title  
Inset Stopping/Parking Details



Drawing Status  
**GUIDANCE ISSUE No 2**

Drawn PCL	Designed TFL	Scale As shown	Size A3
--------------	-----------------	-------------------	------------

Drawing No. TFL/SG13	Rev 6
-------------------------	----------

With reference to designer's duties under the Construction (Design and Management) Regulations 2007, design teams are reminded to use a hierarchy of control, so far as is reasonably practical, to i) eliminate the hazard, ii) reduce the risk iii) provide relevant information. Key risks include manual handling and dust inhalation.

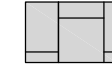
**Legend**

-  150mm Granite kerb, fine picked
-  Concrete flag, nominally 900x600x65mm
-  Road markings in thermoplastic screed or equivalent

**Notes**

1. All paving to be laid on a 150mm thick type c7.5p concrete sub base extending 1000mm from back of kerb unless otherwise specified. The remaining area of footway to be laid on 100mm thick type c7.5p concrete sub base unless otherwise stated. All concrete flags and tactile paving to be bedded on a 30mm sand/cement mortar mix, butt jointed, with dry sand brushed into joints. The Resident Engineer should be advised where the preferred depth of construction cannot be achieved on site.
2. Concrete flags to be laid with courses set at 90° to kerb and a minimum overlap bond of 150mm.
3. The bonding of paving to be cut around utility service covers unless directed by the Resident Engineer.
4. Concrete flags should not be cut so that a width less than 300mm remains. Previous courses should be cut to distribute evenly over width.
5. Granite kerbs to be fine picked 150mm x 300mm x 900-1200mm long. Standard kerb height to be 125mm above carriageway.
6. Existing utility service covers in paved areas to be replaced with recessed covers and infilled with matching paving. Covers to be adjusted to suit on site as directed by the Resident Engineer. (Ref Dwgs TFL/SG21 & SG22)
7. Lateral clearance to all street furniture to be 450mm minimum from face of kerb.
8. All work to be carried out in compliance with the requirements of The Manual Handling Operations Regulations 1992 (as amended in 2002).

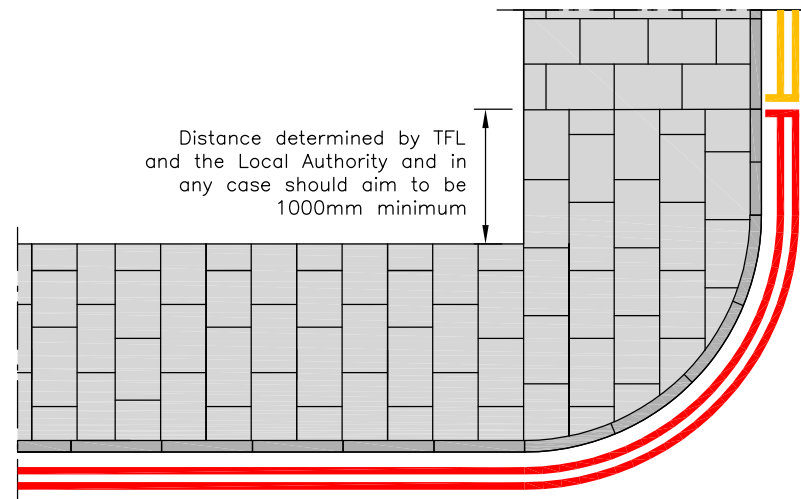

Distance determined by TFL and the Local Authority and in any case should aim to be 1000mm minimum

Plan A  
Scale 1:100

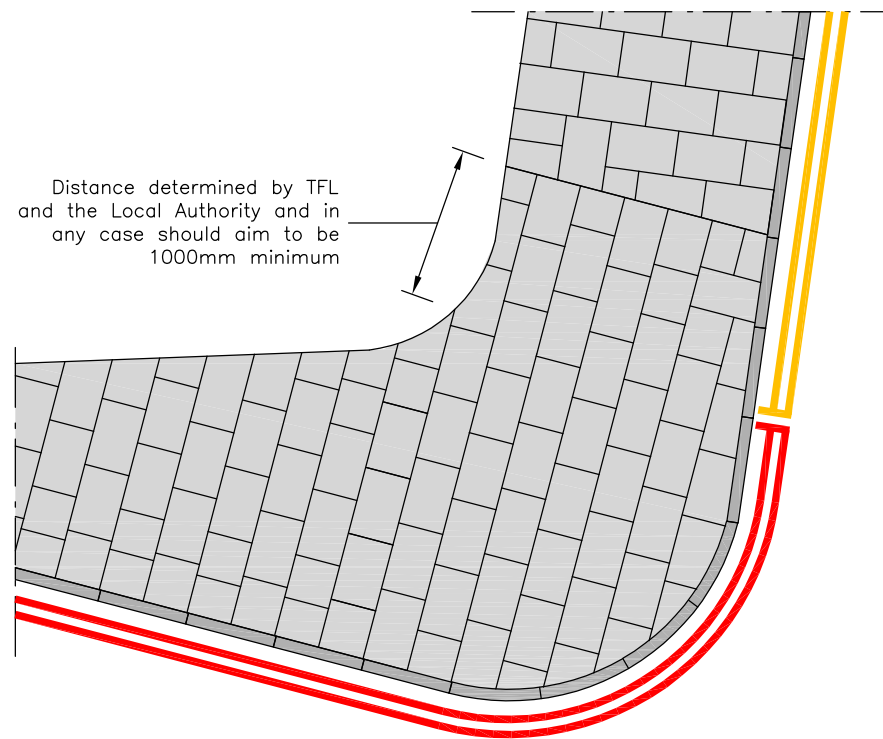

Distance determined by TFL and the Local Authority and in any case should aim to be 1000mm minimum

Plan B  
Scale 1:100

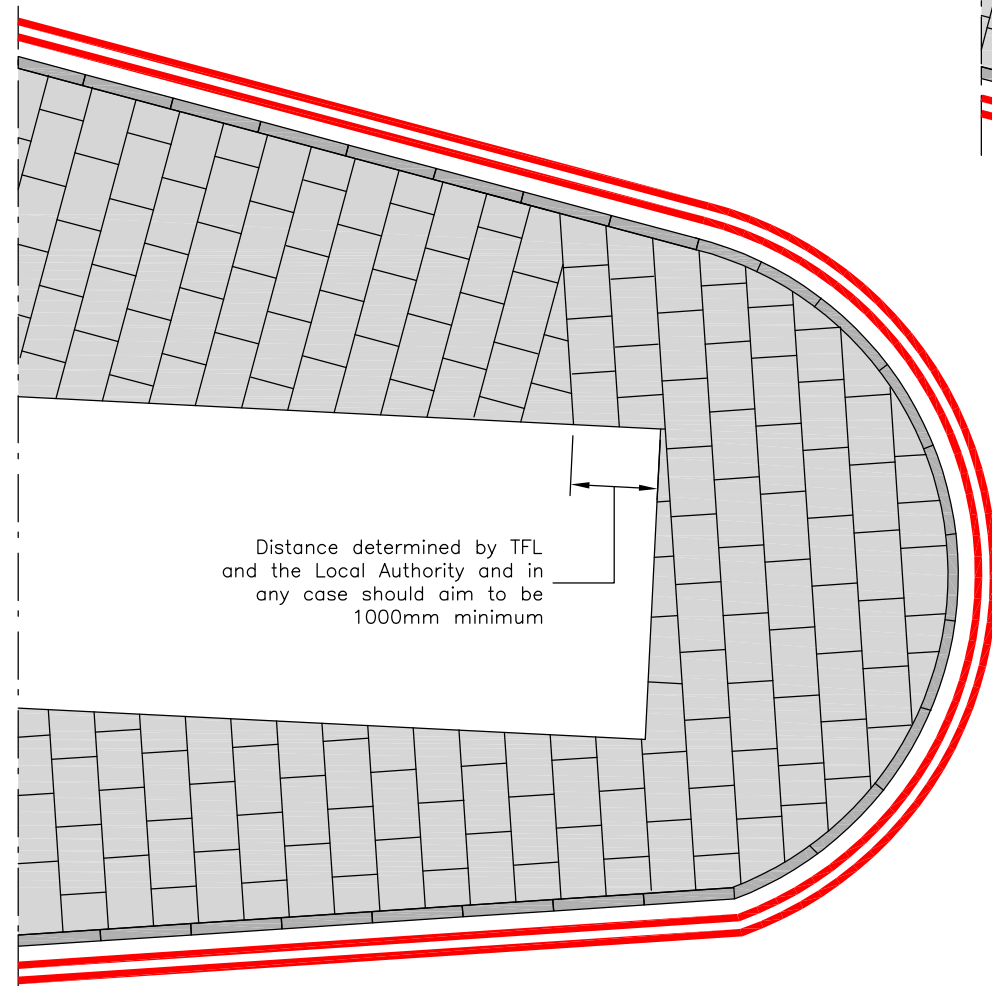

Distance determined by TFL and the Local Authority and in any case should aim to be 1000mm minimum

Plan C  
Scale 1:100

Rev.	Date	Description	Chkd.	App.
4	02/04/08	GUIDANCE ISSUE No 2	MDR	CNR
3	01/04/08	MINOR AMENDMENTS	MDR	CNR
2	10/08/05	GUIDANCE ISSUE No 1	SK	RD
1	07/04/05	Client amendments	RD	IH
0	25/02/05	Original Issue	RD	IH



Project  
Streetscape Guidance

Drawing Title  
Paving Details for Directional Changes





Drawing Status  
**GUIDANCE ISSUE No 2**

Drawn PCL	Designed TFL	Scale 1:100	Size A3
--------------	-----------------	----------------	------------

Drawing No. TFL/SG14	Rev 4
-------------------------	----------

With reference to designer's duties under the Construction (Design and Management) Regulations 2007, design teams are reminded to use a hierarchy of control, so far as is reasonably practical, to i) eliminate the hazard, ii) reduce the risk iii) provide relevant information. Key risks include manual handling and dust inhalation.

**Legend**

-  150mm Granite kerb, fine picked
-  Concrete flag, nominally 900x600x65mm
-  Road markings in thermoplastic screed or equivalent
-  Tree pit
-  Tree

**Notes**

1. Refer to Streetscape Guidance for further requirements.
2. Lateral clearance to all street furniture to be 450mm minimum from face of kerb.

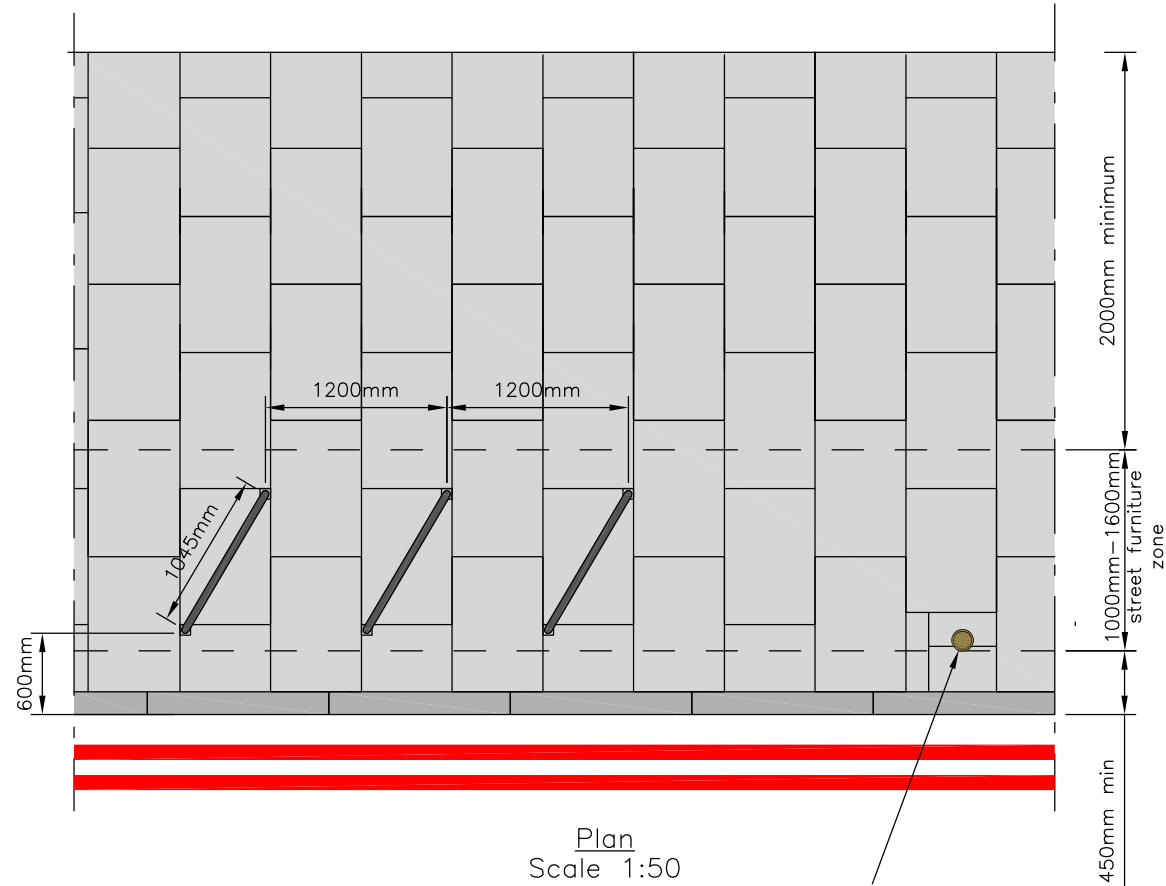
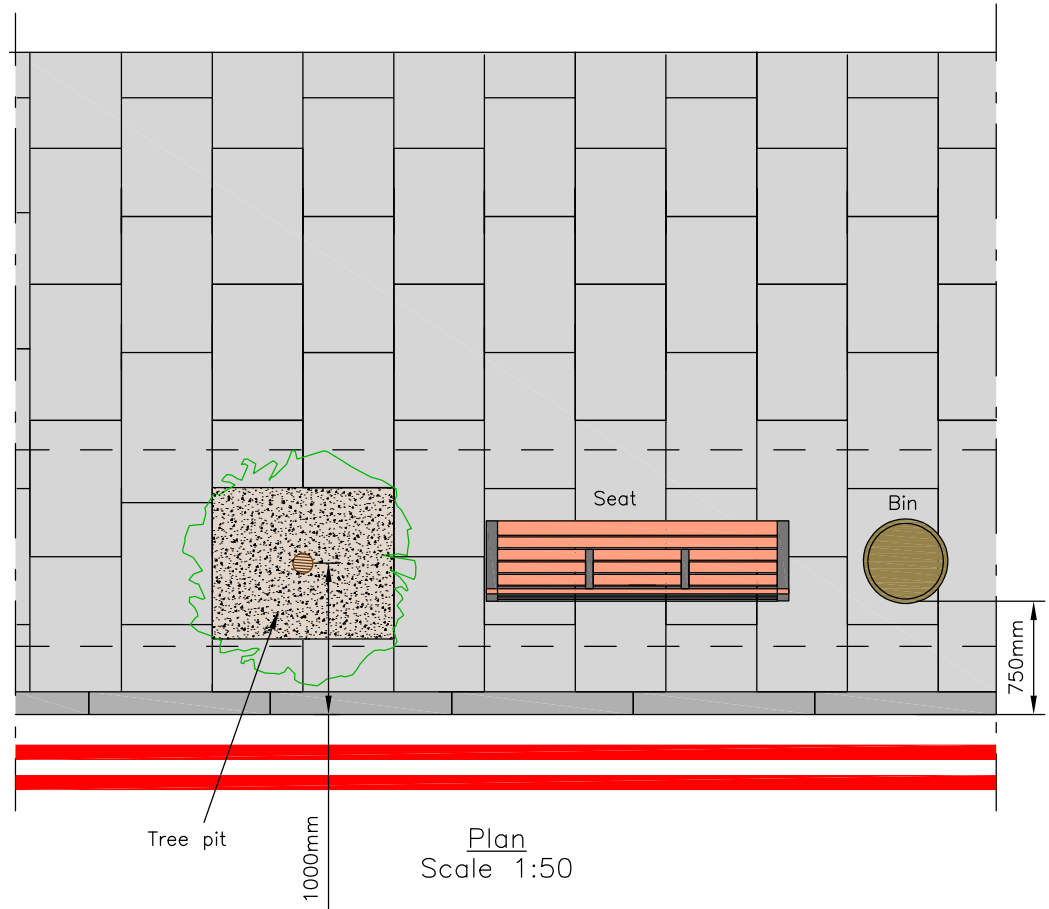

Refer to Details A & B on Drg TFL/SG06 for treatment types

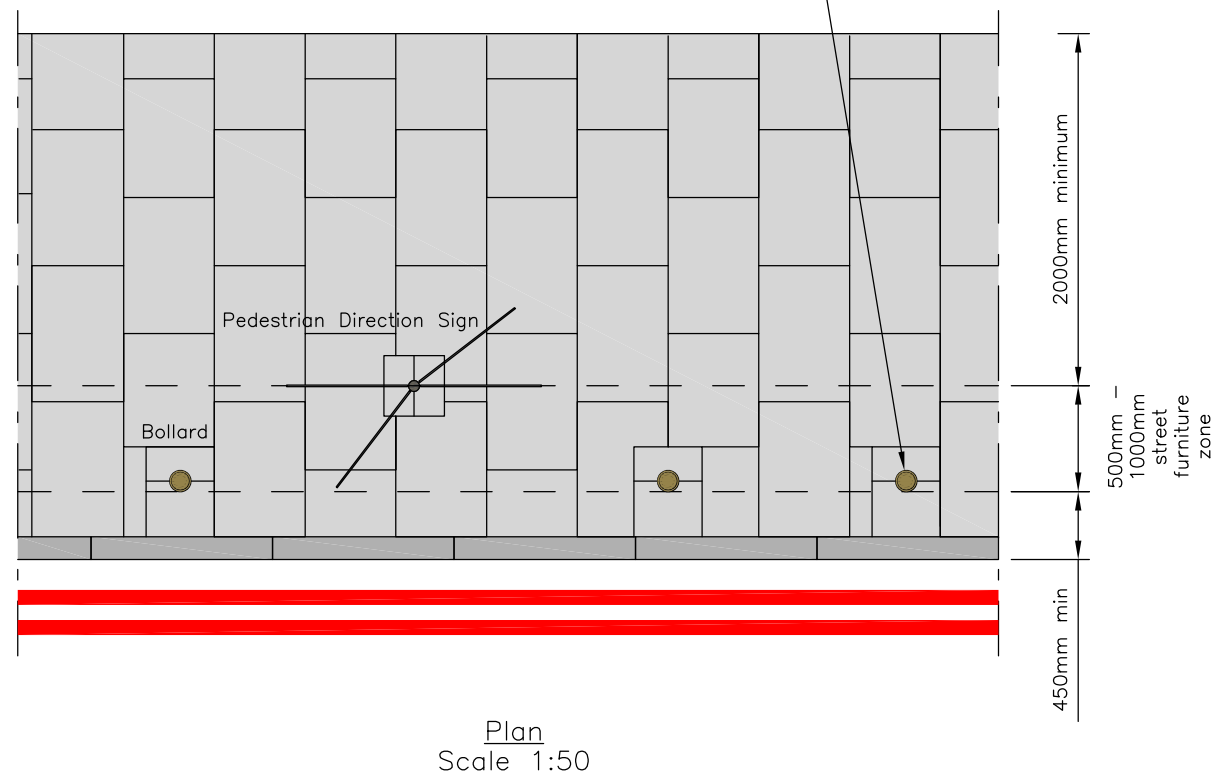
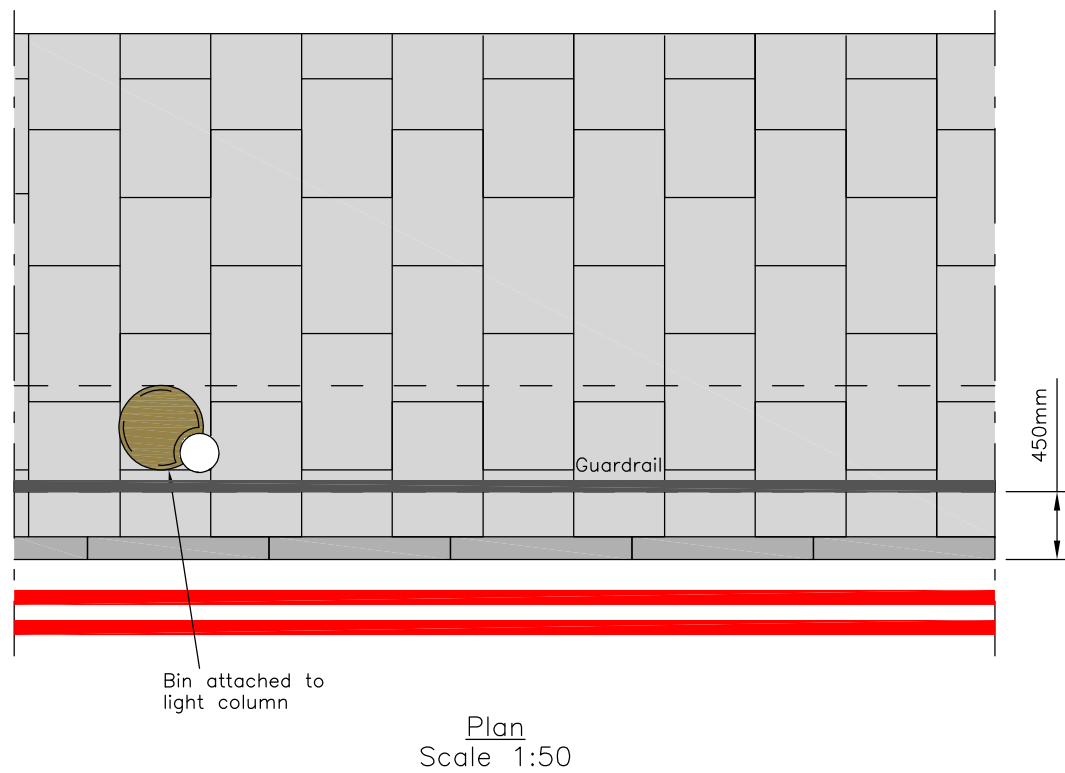





5	02/04/08	GUIDANCE ISSUE No 2	MDR	CNR
4	17/11/07	MINOR AMENDMENTS	SK	RD
3	10/08/05	GUIDANCE ISSUE No 1	SK	RD
2	02/08/05	CLIENT AMENDMENTS	RD	IH
1	10/06/05	MINOR AMENDMENTS	RD	IH
0	25/02/05	Original Issue	RD	IH
Rev.	Date	Description	Chkd.	App.



Project			
Streetscape Guidance			
Drawing Title			
Street Furniture Layout Footway Widths Between 2.95m and 4.05m			
Drawing Status			
<b>GUIDANCE ISSUE No 2</b>			
Drawn PCL	Designed TFL	Scale 1:50	Size A3
Drawing No. TFL/SG15			Rev 5

With reference to designer's duties under the Construction (Design and Management) Regulations 2007, design teams are reminded to use a hierarchy of control, so far as is reasonably practical, to i) eliminate the hazard, ii) reduce the risk iii) provide relevant information. Key risks include manual handling and dust inhalation.

**Legend**

-  150mm Granite kerb, fine picked
-  Concrete flag, nominally 900x600x65mm
-  Road markings in thermoplastic screed or equivalent
-  Tree pit
-  Tree

**Notes**

1. Refer to Streetscape Guidance for further requirements.
2. Lateral clearance to all street furniture to be 450mm minimum from face of kerb.

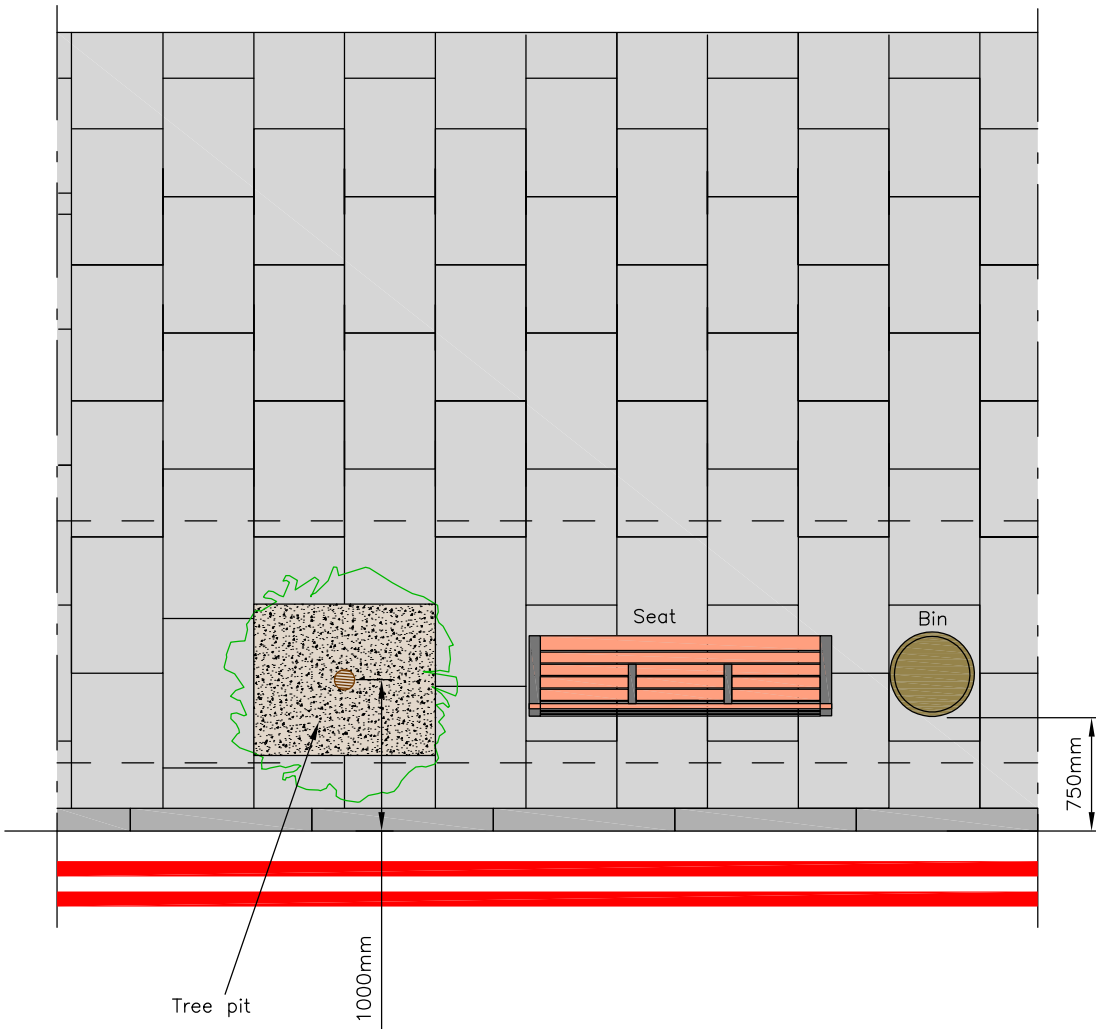

Plan  
Scale 1:50

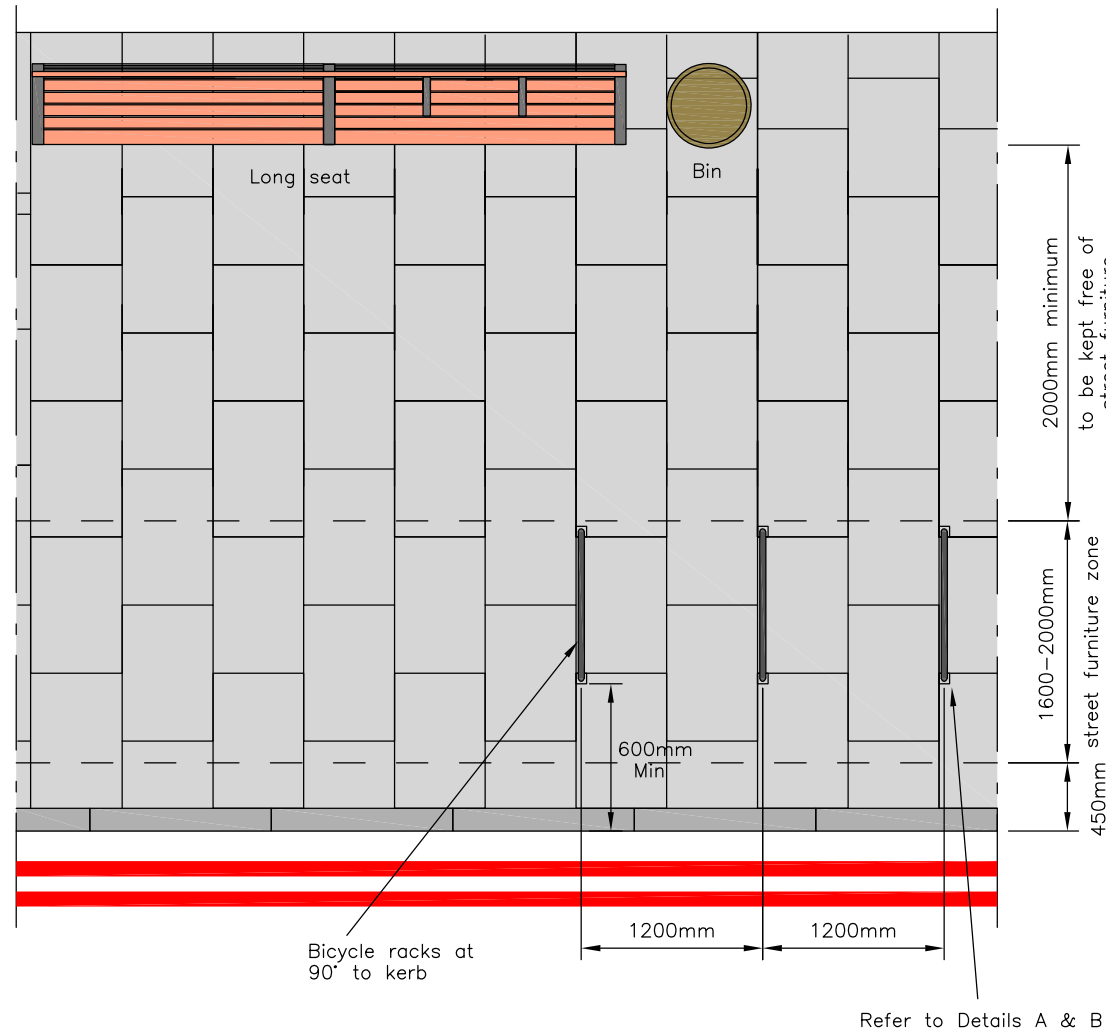

Plan  
Scale 1:50

Refer to Details A & B on Drg TFL/SG06 for treatment types

Rev.	Date	Description	Chkd.	App.
4	02/04/08	GUIDANCE ISSUE No 2	MDR	CNR
3	17/12/07	MINOR AMENDMENTS	GSV	LD
2	10/08/05	GUIDANCE ISSUE No 1	SK	RD
1	10/06/05	MINOR AMENDMENTS	RD	IH
0	25/02/05	Original Issue	RD	IH



Project			
Streetscape Guidance			
Drawing Title			
Street Furniture Layout Footway Width More Than 4.05m			
Drawing Status			
<b>GUIDANCE ISSUE No 2</b>			
Drawn PCL	Designed TFL	Scale 1:50	Size A3
Drawing No. TFL/SG16			Rev 4



Notes

1. All works to be carried out to the relevant TFL specification
2. Duct layout is indicative only & subject to site conditions
3. Traffic signal poles must be positioned to provide a minimum lateral clearance of 450mm from all signal equipment to kerb face.
4. All poles to be installed directly into ground
5. Pushbuttons to be mounted at 45° to kerb on all poles
6. All pushbuttons to have tactile rotating cones
7. All pushbuttons to have audibles

Period	Signal to vehicles	Signal to pedestrian	Durations (seconds)
A	Green	Red	7 to 20
B	Amber	Red	3
C	Red	Red	1 to 3
D	Red	Green	5 to 7
E	Red	Flashing Green	0 to 2
F	Flashing Amber	Flashing Green	6 to 18
G	Flashing Amber	Red	1 to 2

Table 1: Pelican crossing timings

With reference to designer's duties under the Construction (Design and Management) Regulations 2007, design teams are reminded to use a hierarchy of control, so far as is reasonably practical, to i) eliminate the hazard, ii) reduce the risk iii) provide relevant information. Key risks include manual handling and dust inhalation.

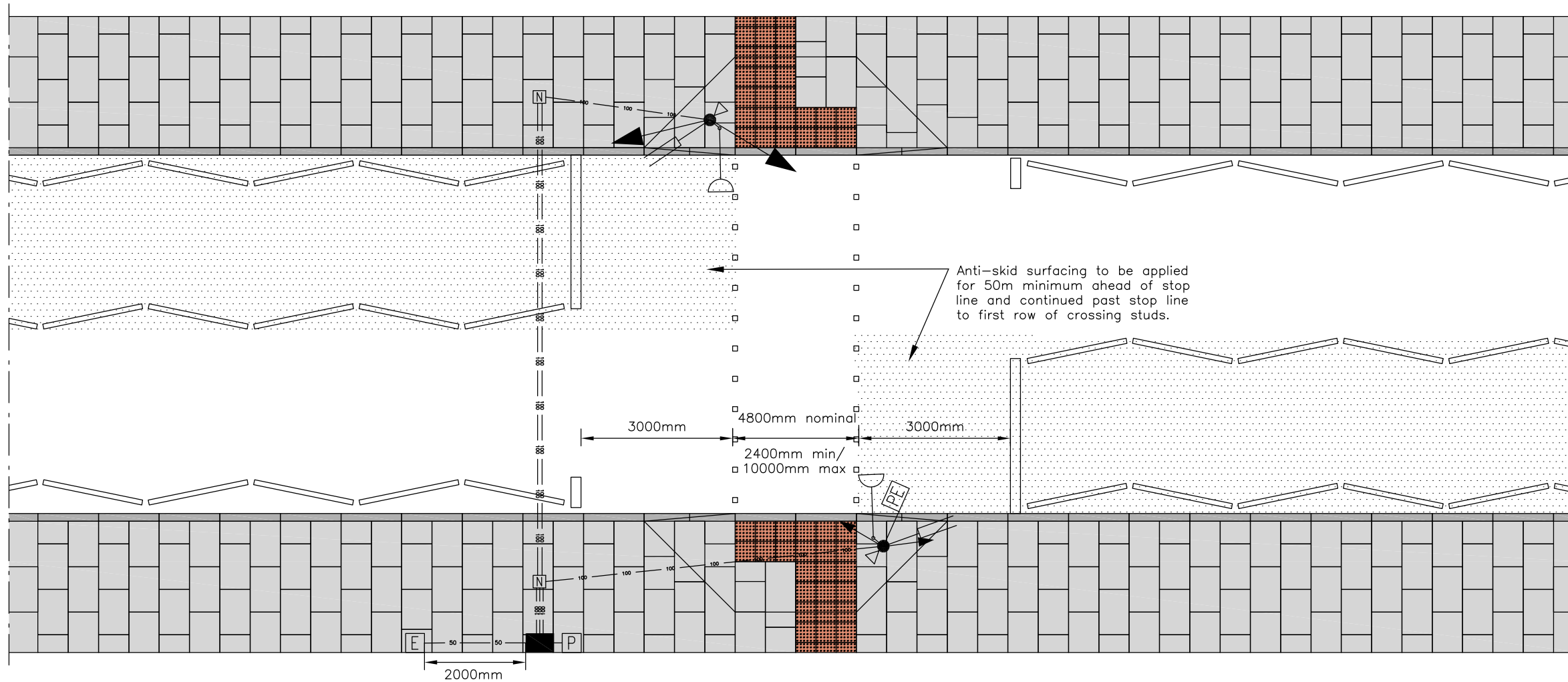

Plan Scale 1:100

Engineer to specify width of crossing (between stud lines). Width should be in increments of 400 mm to accommodate exact number of standard 400x400mm blister paving slabs.

Ideal tactile arrangement as shown with 2 rows of blister for the width of the crossing and a tail of 3 blister slabs wide from the right hand side of the crossing extending to back of footway or to 5000mm maximum.

Legend:

- Red blister paving: concrete modular, 400x400x65mm
- Concrete flag, nominally 900x600x65mm
- 150mm Granite kerb, fine picked
- Dropper granite kerb, fine picked
- Anti-skid surfacing
- 3 aspect signal (rag) on pole
- 2 aspect pedestrian signal front-mounted
- Pedestrian pushbutton
- Microwave detector
- Proposed drawpit
- Prop. 50mm ø cable duct run
- Prop. 100mm ø cable duct run
- Photo-electric cell
- Electricity supply pillar
- Post jointing large/small
- Controller

Rev.	Date	Description	Chkd.	App.
3	02/04/08	GUIDANCE ISSUE No 2	MDR	CNR
2	17/11/07	MINOR AMENDMENTS	GSV	LD
1	10/08/05	GUIDANCE ISSUE No 1	SK	RD
0	25/02/05	Original Issue	RD	IH



Project  
Streetscape Guidance

Drawing Title  
Pelican Crossing—  
Signal Details

Drawing Status  
**GUIDANCE ISSUE No 2**

Drawn PCL	Designed TFL	Scale 1:100	Size A3
--------------	-----------------	----------------	------------

Drawing No. TFL/SG17	Rev 3
-------------------------	----------

With reference to designer's duties under the Construction (Design and Management) Regulations 2007, design teams are reminded to use a hierarchy of control, so far as is reasonably practical, to i) eliminate the hazard, ii) reduce the risk iii) provide relevant information. Key risks include manual handling and dust inhalation.

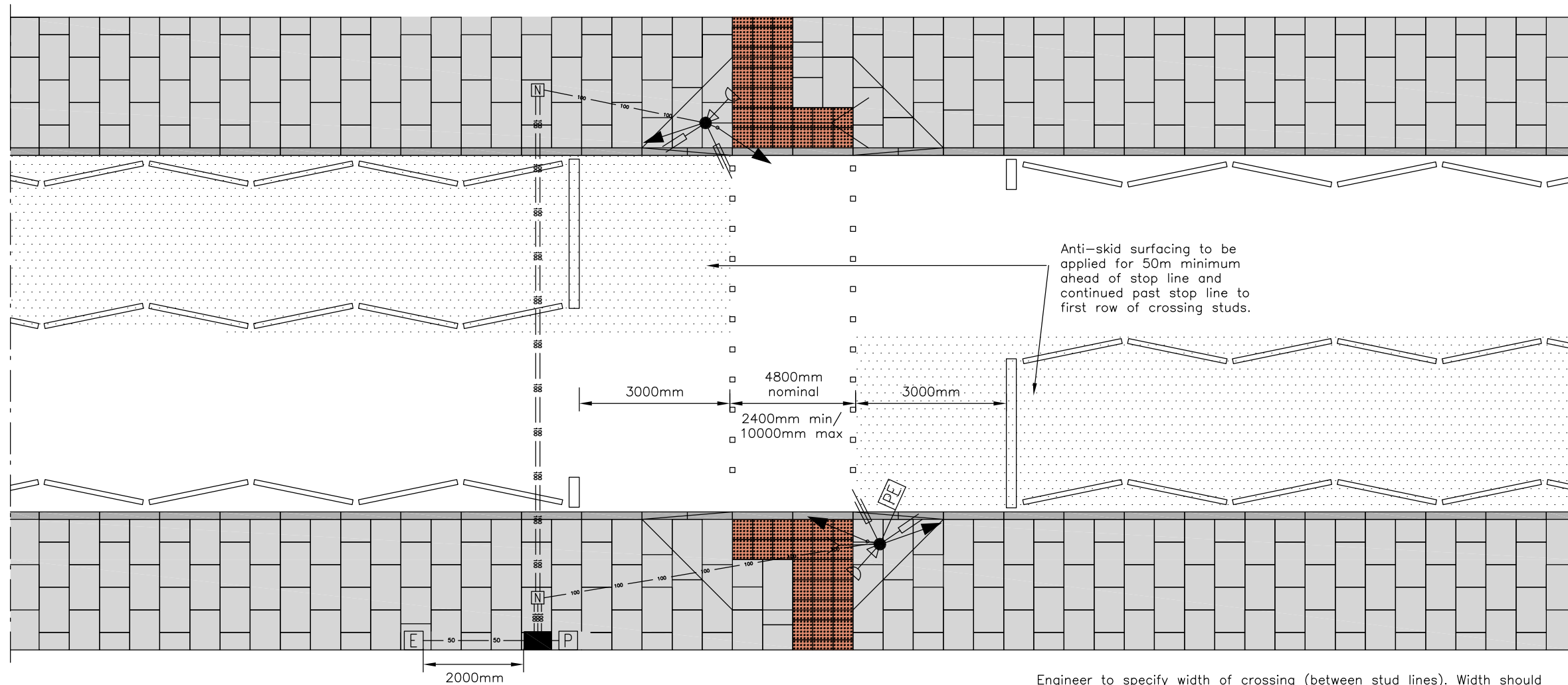

Plan  
Scale 1:100

Engineer to specify width of crossing (between stud lines). Width should be in increments of 400 mm to accommodate exact number of standard 400x400mm blister paving slabs.

Ideal tactile arrangement as shown with 2 rows of blister for the width of the crossing and a tail of 3 blister slabs wide from the right hand side of the crossing extending to back of footway or to 5000mm maximum.

Legend

- Red blister paving: concrete modular, 400x400x65mm
- 150mm Granite kerb, fine picked
- Dropper granite kerb, fine picked
- Concrete flag, nominally 900x600x65mm
- Anti-skid surfacing
- 3 aspect signal (RAG) on pole
- Pedestrian demand unit for use on puffin crossings
- Microwave detector
- Microwave detector (pedestrian kerbside)
- Microwave detector (pedestrian on-crossing)
- Proposed drawpit
- Prop. 50mm  $\varnothing$  cable duct run
- Prop. 100mm  $\varnothing$  cable duct run
- Photo-electric cell
- Electricity supply pillar
- Post jointing large/small
- Controller

3	02/04/08	GUIDANCE ISSUE No 2	MDR	CNR
2	17/11/07	MINOR AMENDMENTS	GSV	LD
1	10/08/05	GUIDANCE ISSUE No 1	SK	RD
0	25/02/05	Original issue	RD	IH
Rev.	Date	Description	Chkd.	App.



Project			
Streetscape Guidance			
Drawing Title			
Puffin Crossing— Signal Details			
Drawing Status			
<b>GUIDANCE ISSUE No 2</b>			
Drawn PCL	Designed TFL	Scale As shown	Size A3
Drawing No. TFL/SG18			Rev 3

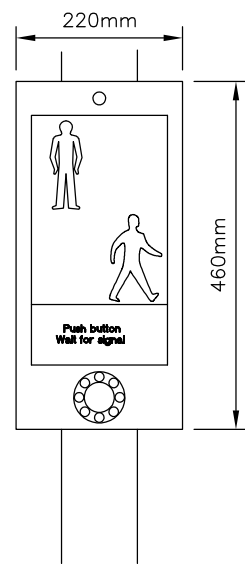

Figure 1  
Scale 1:10

Period	Signal to Vehicles	Signal to Pedestrians	Durations (seconds)
1	Green	Red	7/20
2	Amber	Red	3
3	Red	Red	1 to 3
4	Red	Green	5
5	Red	Red (fix)	3
6	Red	Red (ext)	0 – 22
7	Red	Red (max)	3
8	Red	Red (gap)	0 to 3
9	Red & Amber	Red	2

Table 1: Puffin crossing timings

Notes

- All works to be carried out to the relevant TFL specification
- Duct layout is indicative only & subject to site conditions
- Traffic signal poles must be positioned to provide a minimum lateral clearance of 450mm from all signal equipment to kerb face.
- All poles to be installed directly into ground
- Pushbuttons to be mounted at 45° to kerb on all poles
- All pushbuttons to have tactile rotating cones
- All pushbuttons to have audibles
- Pushbutton plates to be as shown in Figure 1 (or similar)

With reference to designer's duties under the Construction (Design and Management) Regulations 2007, design teams are reminded to use a hierarchy of control, so far as is reasonably practical, to i) eliminate the hazard, ii) reduce the risk iii) provide relevant information. Key risks include manual handling and dust inhalation.

Notes

1. Fine picking of kerbs to stop 75mm before bottom of kerbs.
2. Concrete kerbs to the same dimensions may be used where adjacent kerbs are concrete.
3. All work must be carried out in compliance with the requirements of The Manual Handling Operations Regulations 1992 (as amended in 2002).

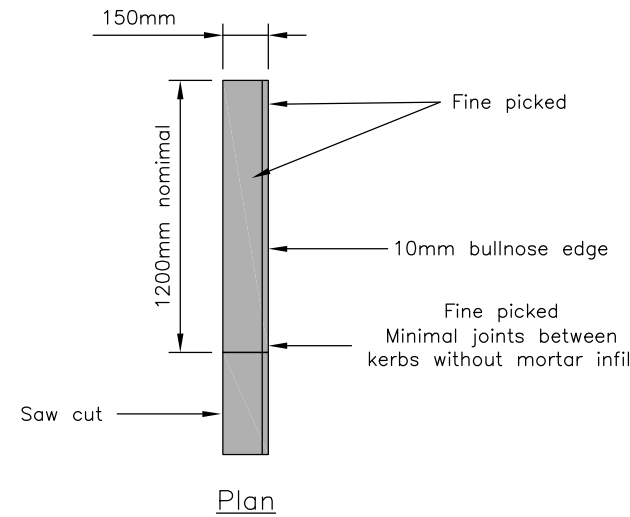
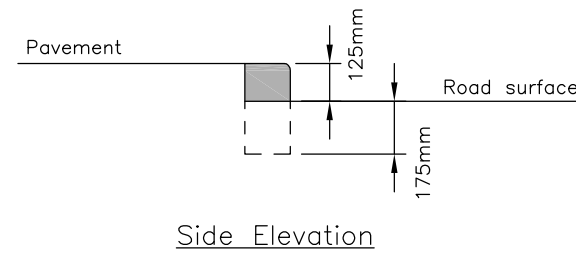
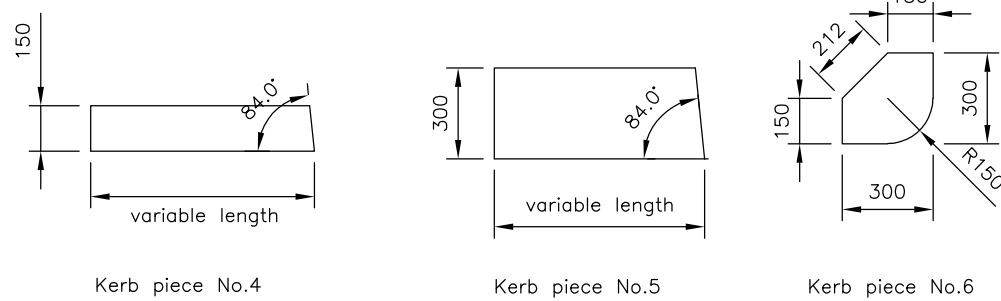
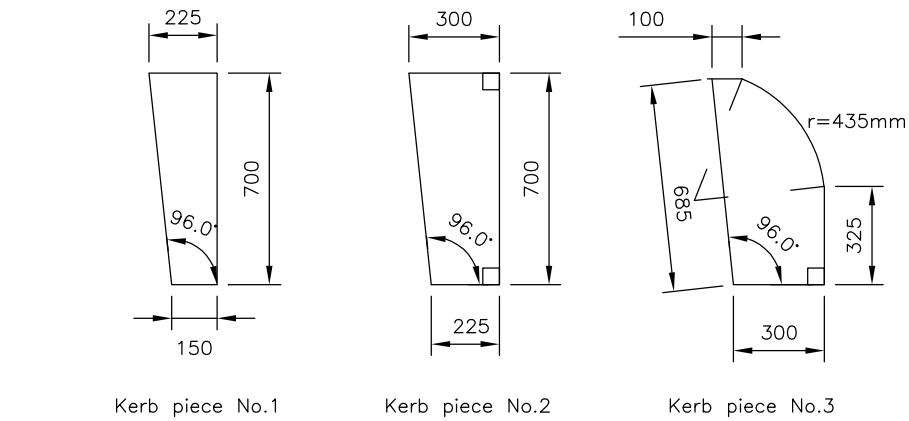

Typical Straight Kerb  
Not to scale

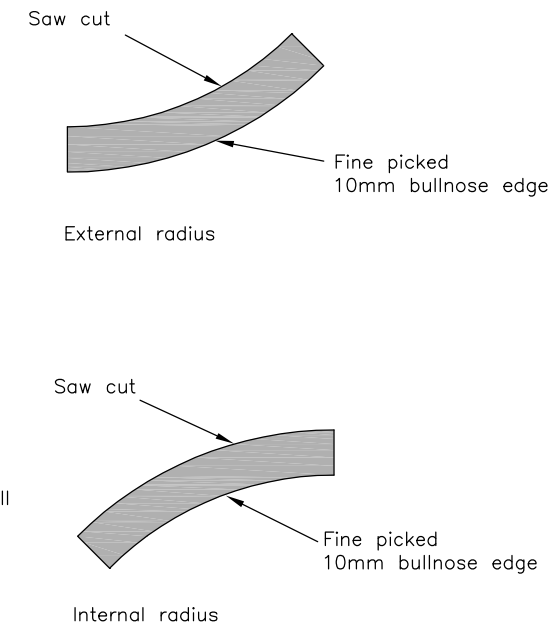

Typical Plan of Curved Kerbs  
Not to scale

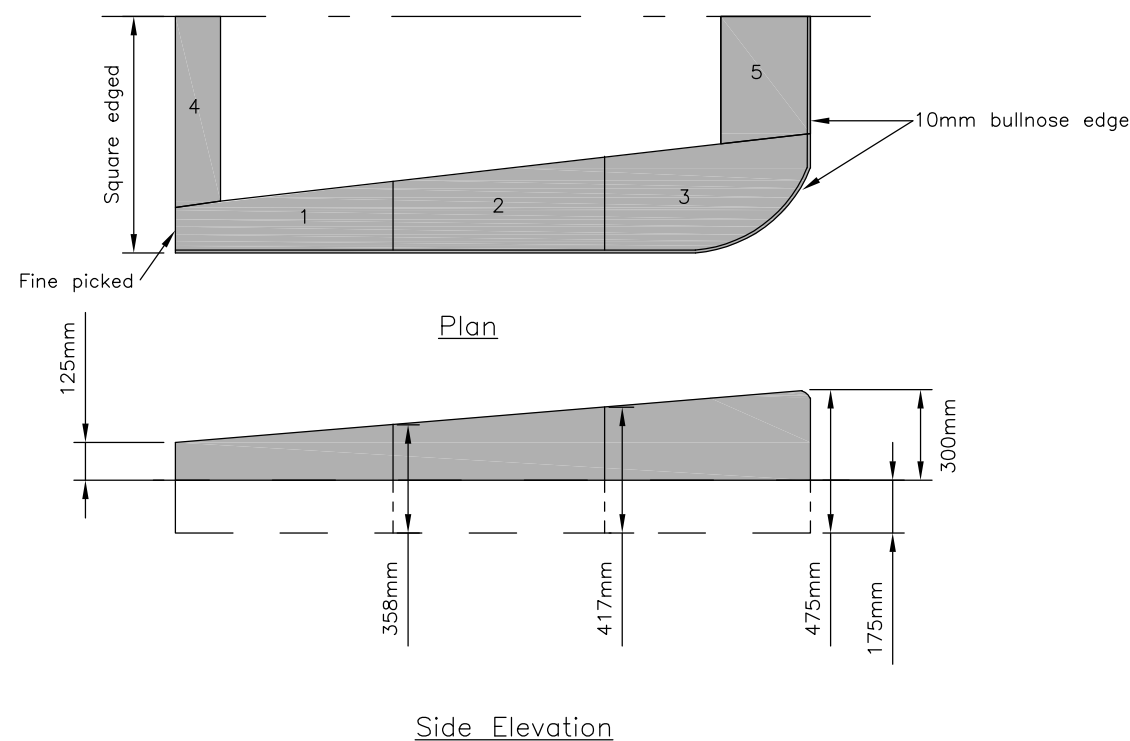

Refuge Island Kerbs Option A  
Scale 1:25

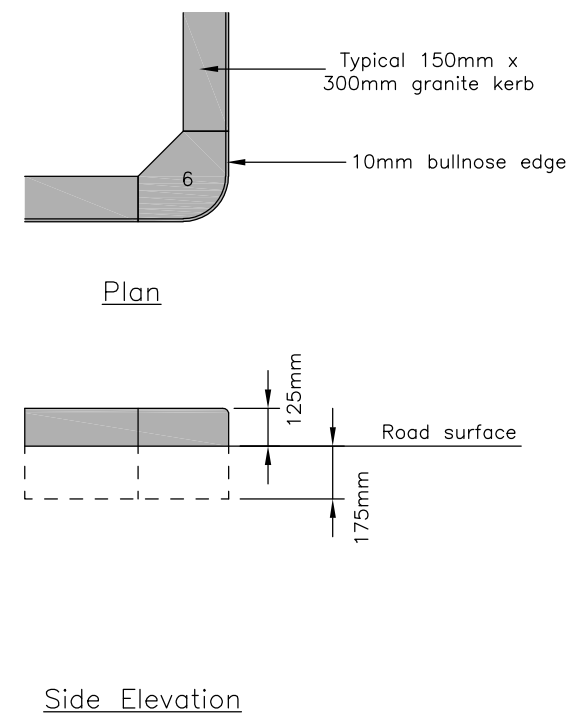

Refuge Island Kerbs Option B  
Scale 1:25

6	30/06/08	GUIDANCE ISSUE No 2	MDR	CNR
5	02/04/08	MINOR AMENDMENTS	MDR	CNR
4	01/04/08	MINOR AMENDMENTS	MDR	CNR
3	10/08/05	GUIDANCE ISSUE No 1	SK	RD
2	10/06/05	MINOR AMENDMENTS	RD	IH
1	07/04/05	Client amendments	RD	IH
0	25/02/05	Original Issue	RD	IH
Rev.	Date	Description	Chkd.	App.



Project  
Streetscape Guidance

Drawing Title  
Kerb Details

Drawing Status  
**GUIDANCE ISSUE No 2**

Drawn PCL	Designed TFL	Scale As shown	Size A3
--------------	-----------------	-------------------	------------

Drawing No. TFL/SG19	Rev 6
-------------------------	----------



With reference to designer's duties under the Construction (Design and Management) Regulations 2007, design teams are reminded to use a hierarchy of control, so far as is reasonably practical, to i) eliminate the hazard, ii) reduce the risk iii) provide relevant information. Key risks include manual handling and dust inhalation.

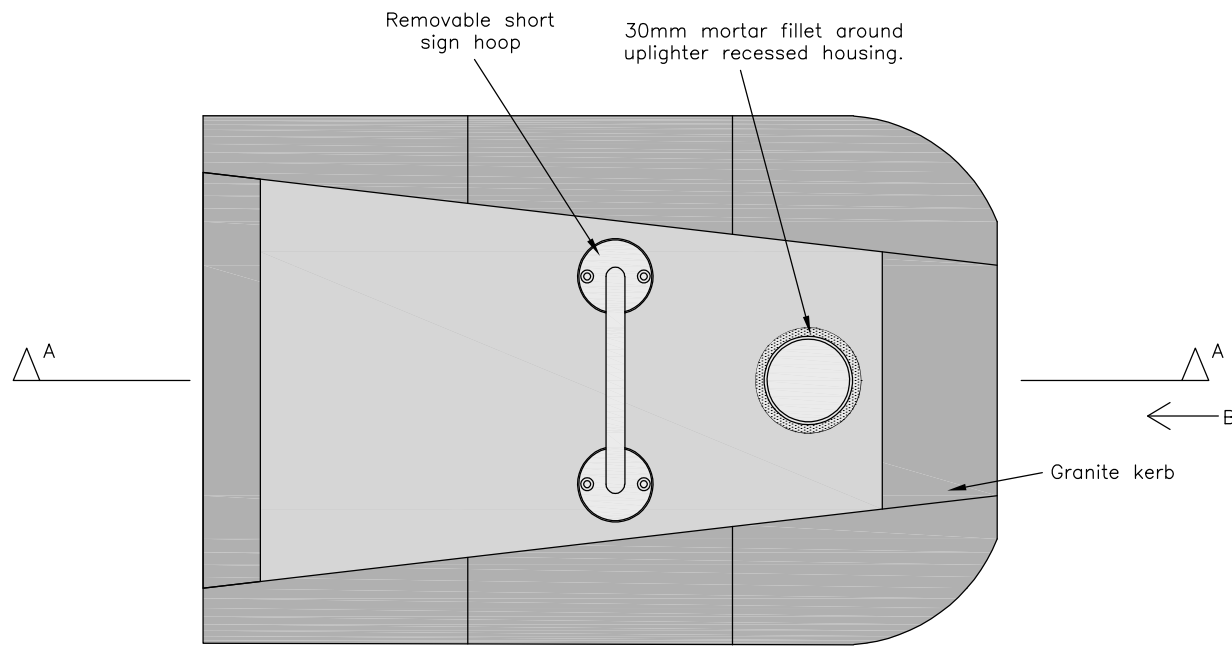

Plan  
Scale 1:20

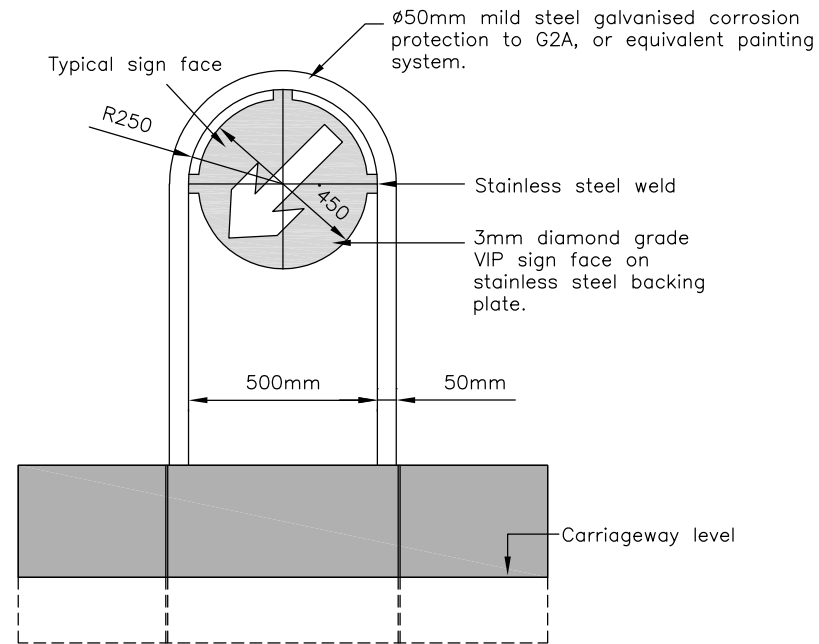

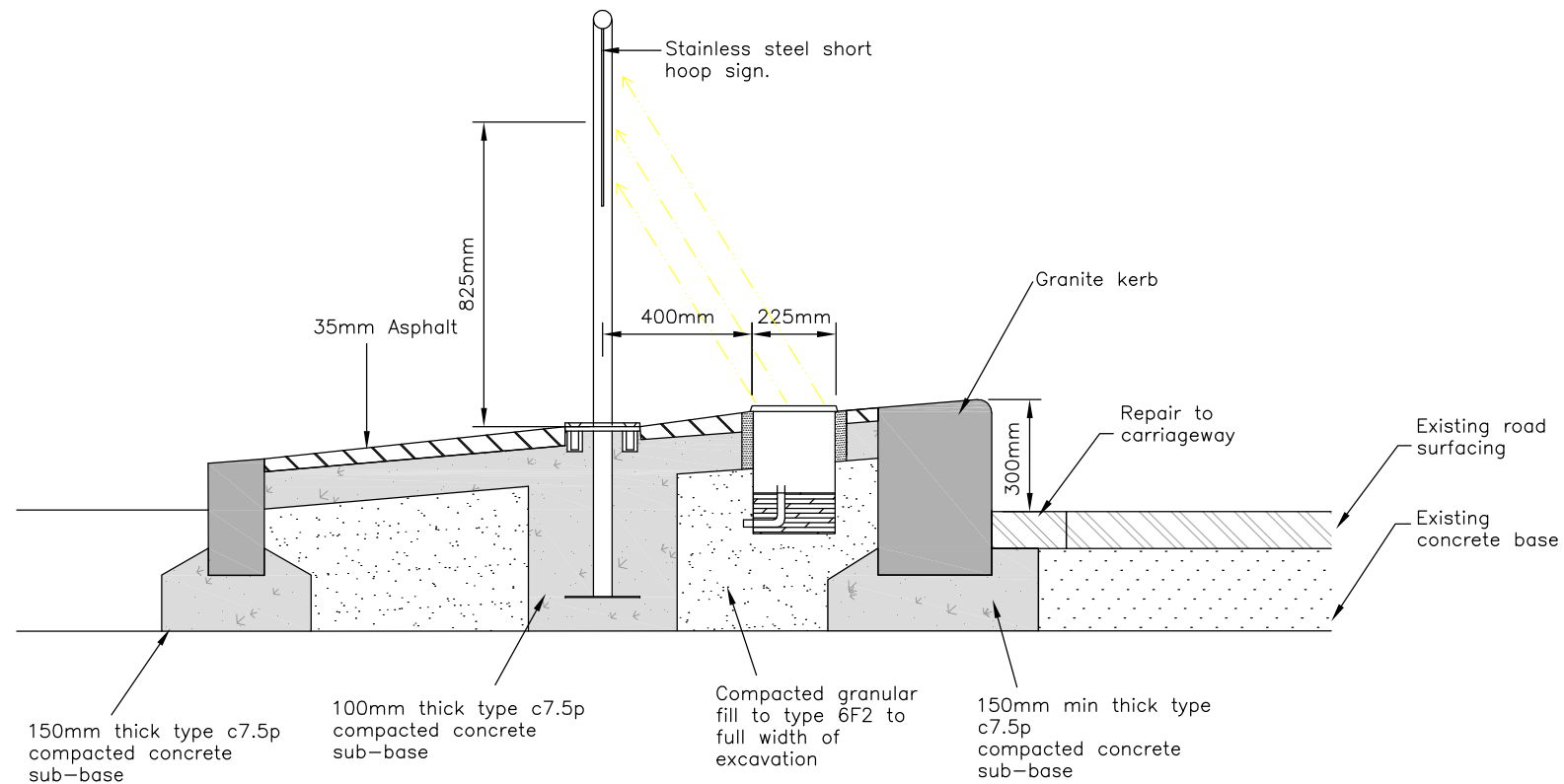

Elevation B  
Scale 1:20



Section A-A  
Scale 1:20

Legend

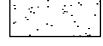
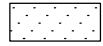
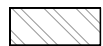
-  Asphalt surfacing
-  Concrete type c7.5p
-  Sub base type 1
-  Road base concrete
-  Re-laid wearing course

Notes

1. All dimensions in millimetres unless otherwise stated.
2. Uplighter to be fitted with 60° grille and stainless steel bezel.
3. Uplighter to be centred on sign face.
4. Top of surface of stainless steel bezel to be flush with final surface.
5. Uplighter to be 'cool touch'
6. Lateral clearance to all street furniture to be 450mm minimum from face of kerb.

3	02/04/08	GUIDANCE ISSUE No 2	MDR	CNR
2	18/01/08	MINOR AMENDMENTS	GSV	LD
1	10/08/05	GUIDANCE ISSUE No 1	SK	RD
0	25/02/05	Original issue	RD	IH
Rev.	Date	Description	Chkd.	App.



Project			
Streetscape Guidance			
Drawing Title			
Uplighter and Keep Left Sign			
Drawing Status			
<b>GUIDANCE ISSUE No 2</b>			
Drawn PCL	Designed TFL	Scale 1:20	Size A3
Drawing No. TFL/SG20			Rev 3

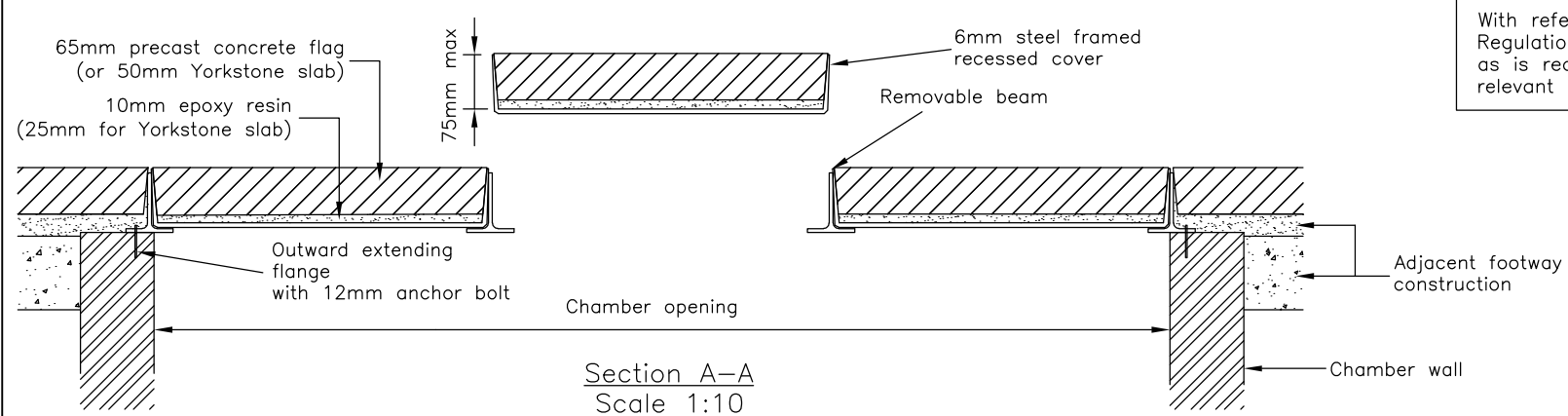

With reference to designer's duties under the Construction (Design and Management) Regulations 2007, design teams are reminded to use a hierarchy of control, so far as is reasonably practical, to i) eliminate the hazard, ii) reduce the risk iii) provide relevant information. Key risks include manual handling and dust inhalation.

Section A-A  
Scale 1:10

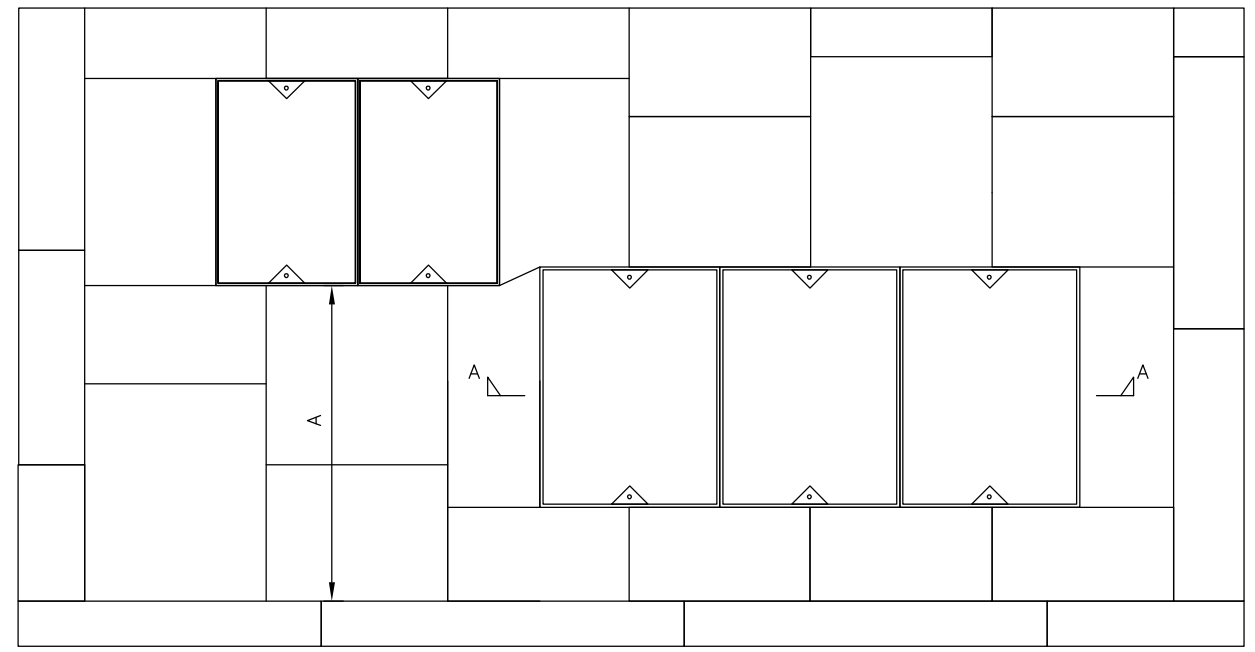

Utility cover in-line with paving (A>900mm)  
Scale 1:25

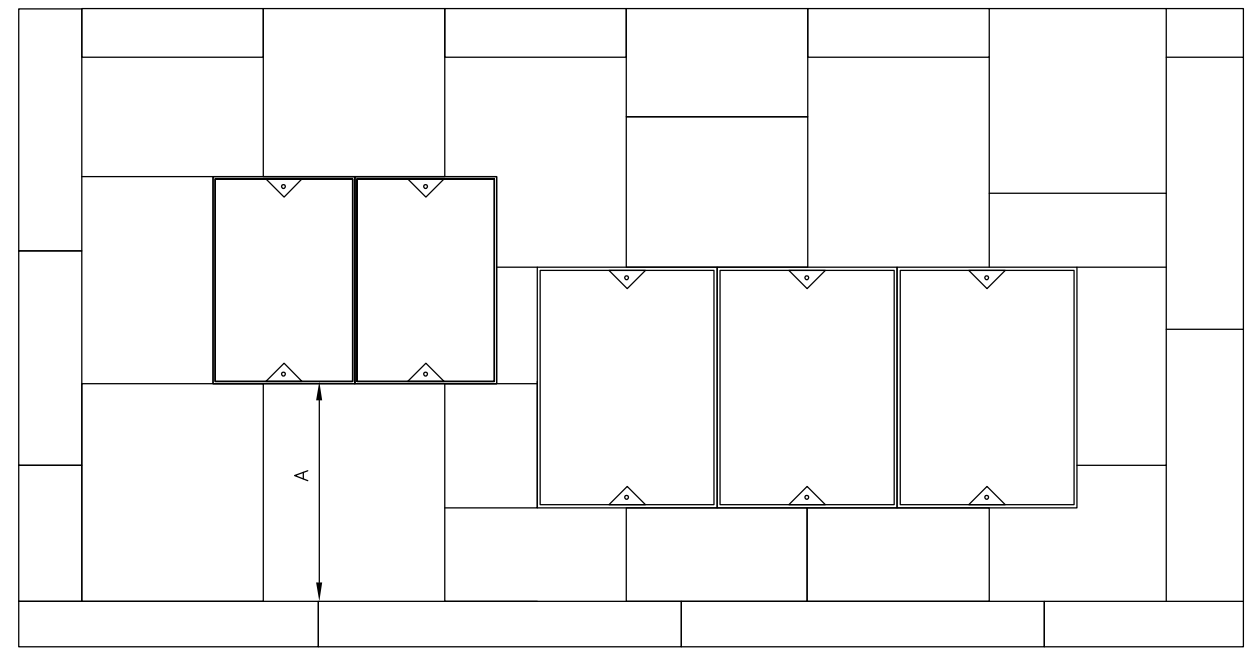

Utility cover in-line with paving (A<900mm)  
Scale 1:25

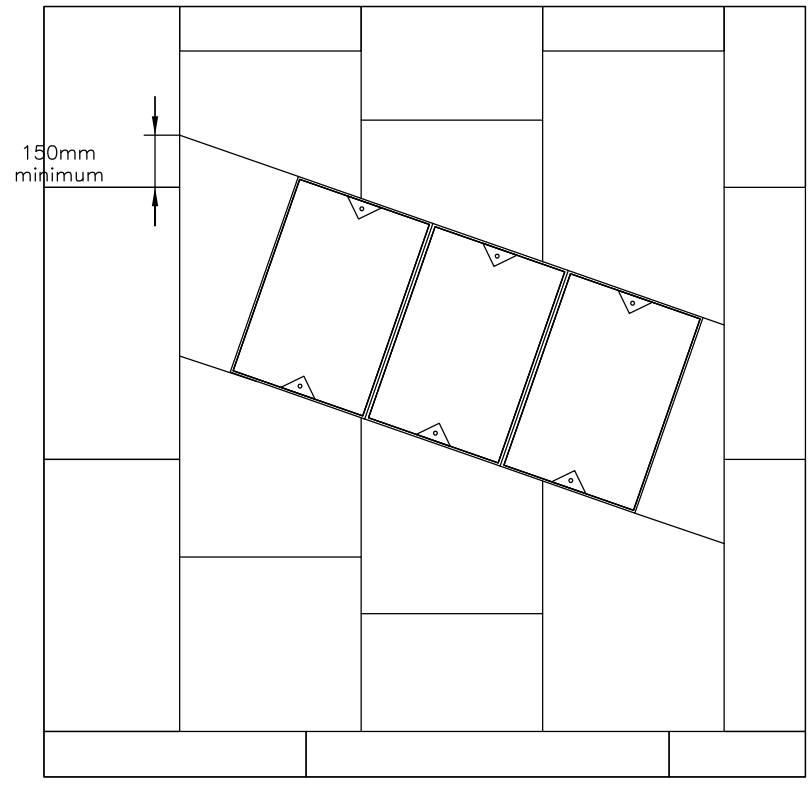

Utility cover not in line with paving  
Scale 1:25

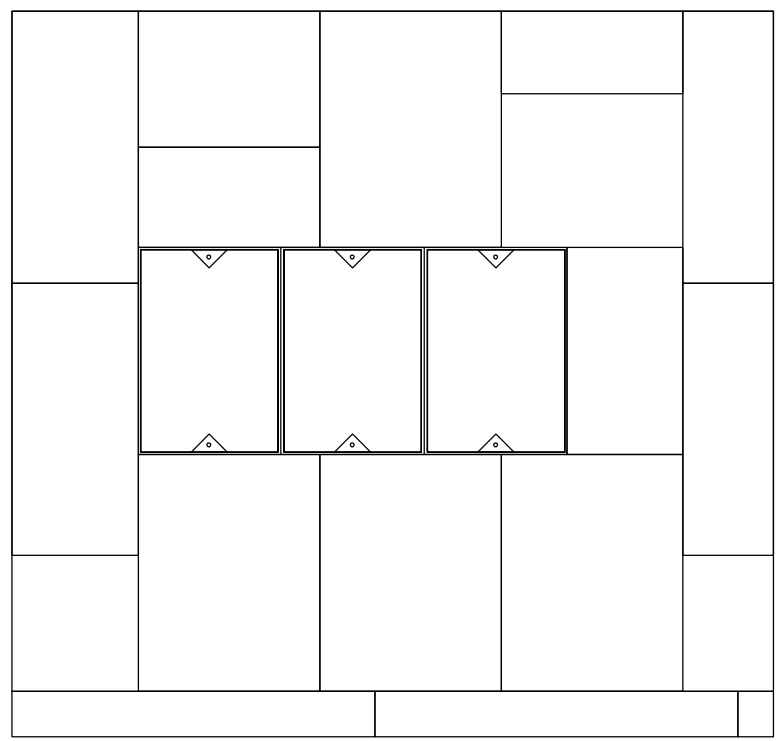

Utility cover in-line with paving  
Scale 1:25

Notes:

- Existing chambers to be surveyed by the contractor to determine appropriate frame and cover to be supplied at each location.
- All frames and covers to be min 6mm thick cast structural steel plate to BS EN 124 formed to required profile and welded using the CO<sub>2</sub> process.
- All frames and covers to be hot dipped galvanised after manufacture to BS729.
- Covers should have 2 No. centralised lifting points. One lifting point should be marked with the BSI kitemark, "EN124" and "B125". The cover should comply to these standards. The other lifting point should be marked with the manufacturer's ID and the utility company ID.
- After brushing in of sand between joints, all covers shall be lifted and sand between the covers and frame removed to ensure future ease of access. The covers shall then be re-fitted.
- Six sets of lifting keys to be provided to the Engineer.
- All work must be carried out in compliance with the requirements of The Manual Handling Operations Regulations 1992 (as amended in 2002).
- Lifting slots to be sized to suit particular utility company's standard lifting key.



Rev.	Date	Description	Chkd.	App.
4	02/04/08	GUIDANCE ISSUE No 2	MDR	CNR
3	19/02/08	MINOR AMENDMENTS	AH	CR
2	10/08/05	GUIDANCE ISSUE No 1	SK	RD
1	02/08/05	CLIENT AMENDMENTS	RD	IH
0	25/02/05	Original Issue	RD	IH



Project			
Streetscape Guidance			
Drawing Title			
Infill Cover- Footway Paving			
Drawing Status			
<b>GUIDANCE ISSUE No 2</b>			
Drawn PCL	Designed TFL	Scale 1:25	Size A3
Drawing No. TFL/SG21			Rev 4

With reference to designer's duties under the Construction (Design and Management) Regulations 2007, design teams are reminded to use a hierarchy of control, so far as is reasonably practical, to i) eliminate the hazard, ii) reduce the risk iii) provide relevant information. Key risks include manual handling and dust inhalation.

Legend

-  Blister paving: concrete modular, 400x400x65mm
-  Chamber wall

Notes

1. Existing chambers to be surveyed by the contractor to determine appropriate frame and cover to be supplied at each location.
2. All frames and covers to be min. 6mm thick cast structural steel plate to BS EN 124 formed to required profile and welded using CO<sub>2</sub> process.
3. All frames and covers to be hot dipped galvanised after manufacture to BS 729.
4. Covers should have 2 No. centralised lifting points. One lifting point should be marked with BSI kitemark, "EN124" and "B125". The cover should comply to these standards. The other lifting point should be marked with the manufacturers ID and the utility company ID.
5. After brushing in of sand, all covers shall be lifted, and sand between the covers and frame removed to ensure future ease of access. The covers shall then be re-fitted.
6. Six sets of lifting keys to be provided to engineer.
7. Slabs aligned to reduce number of cuts for infill covers.
8. All work must be carried out in compliance with the requirements of The Manual Handling Operations Regulations 1992 (as amended in 2002).
9. Lifting slots to be sized to suit particular utility company's standard lifting key.

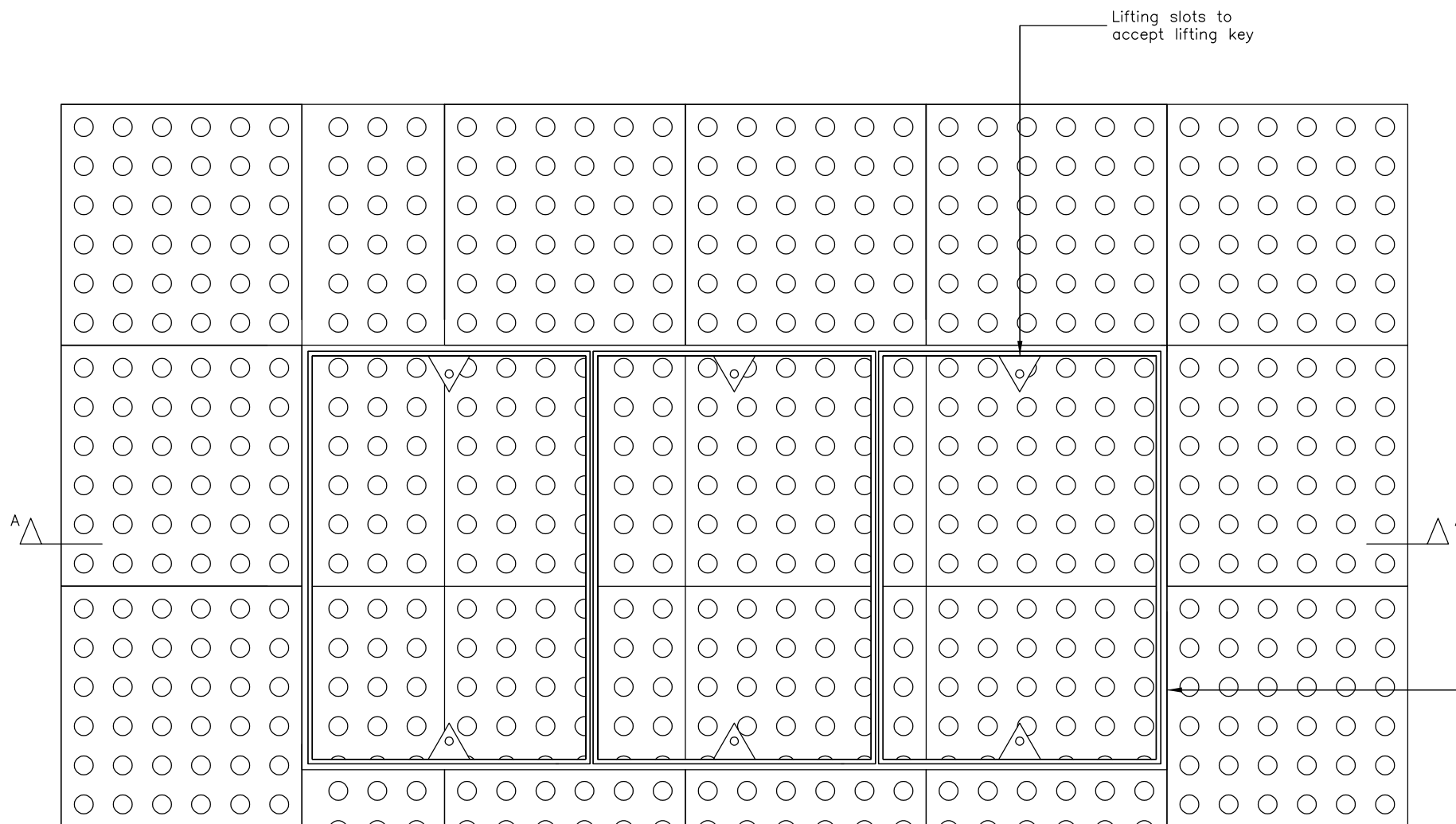
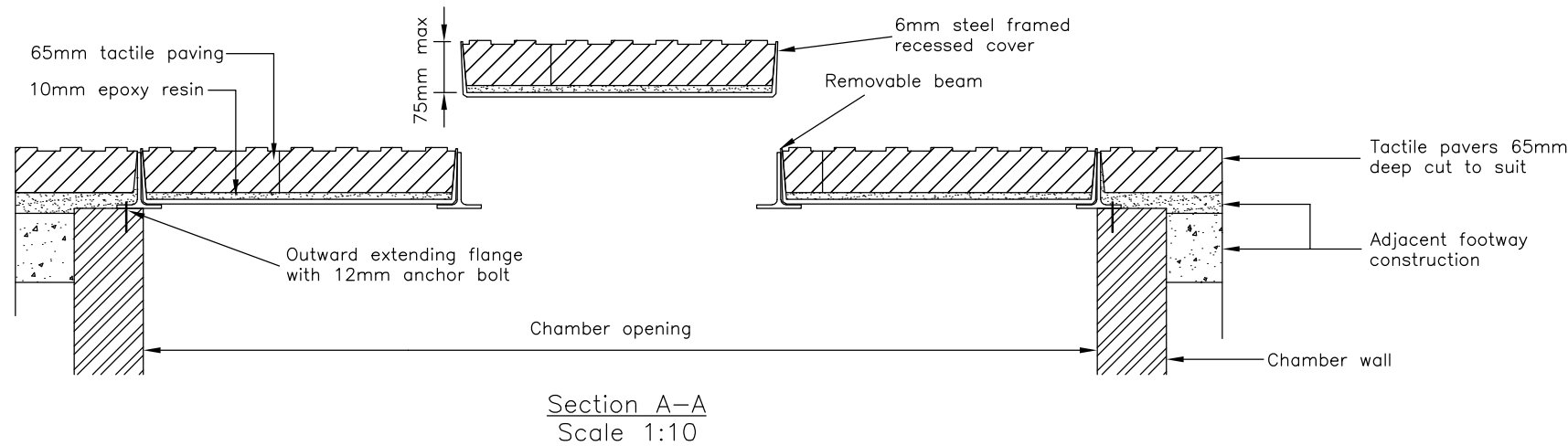

Plan  
Scale 1:10

Typical clear opening chamber size	Number of covers	Typical individual cover size
725 x 225	1	785 x 315
915 x 445	2	485 x 505
610 x 610	2	333 x 670
1310 x 610	3	454 x 670
1690 x 710	5	347 x 770
2285 x 710	6	388 x 770

The number of covers on other sized chambers to be compatible with the above table to allow for one man lift of the covers

Sliding covers to allow greater ease of manual handling

5	30/06/08	GUIDANCE ISSUE No 2	MDR	CNR
4	02/04/08	MINOR AMENDMENTS	MDR	CNR
3	26/03/08	MINOR AMENDMENTS	MDR	CNR
2	19/02/08	MINOR AMENDMENTS	AH	CR
1	10/08/05	GUIDANCE ISSUE No 1	SK	RD
0	25/02/05	Original Issue	RD	IH
Rev.	Date	Description	Chkd.	App.



Project  
Streetscape Guidance

Drawing Title  
Infill Cover-  
Blister Paving

Drawing Status  
**GUIDANCE ISSUE No 2**

Drawn PCL	Designed TFL	Scale 1:10	Size A3
--------------	-----------------	---------------	------------

Drawing No. TFL/SG22	Rev 5
-------------------------	----------